

Dry Vacuum System

Model: ADS V3, ADS V5, ADS V7, ADS V10, ADS V14

Installation Guide

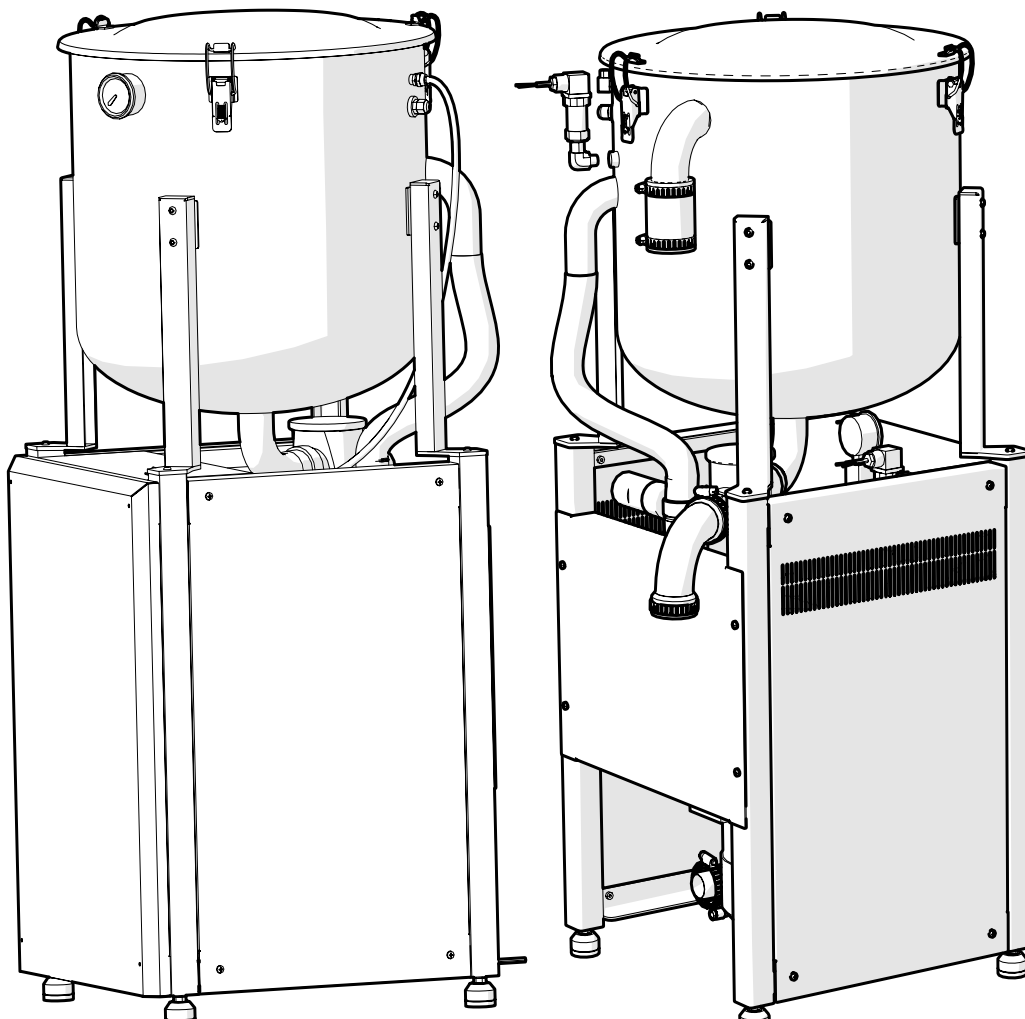

** Picture for Reference Only*

CONTENTS

IMPORTANT SAFETY INSTRUCTIONS..... 2
 Identification of Danger Levels2

BEFORE YOU BEGIN 2
 Recommended Tools3

EQUIPMENT SIZING SPECIFICATIONS..... 3

VACUUM UNIT CLEARANCE REQUIREMENTS 4

VACUUM UNIT INSTALLATION 5
 Before Installation5
 Single Vacuum Unit Installation5
 Single Vacuum Unit - Overhead Intake..... 5
 Single Vacuum Unit - Below Grade Intake..... 6
 Vacuum Unit Leveling Procedure 6
 Vacuum Unit Hose Connections 6
 Connecting the Washdown Waterline 9
 Tandem Vacuum Units Installation9
 Tandem Intake Manifold Assembly..... 9
 Tandem Vacuum Units - Overhead Intake..... 9
 Tandem Vacuum Units - Below Grade Intake 10
 Attaching and Leveling the Intake Manifold.....10
 Connecting the Intake Hose to the Trunk Line..... 11
 Connecting the Exhaust Hoses..... 11
 Connecting Exhaust for Two Vacuum Units 11
 Setting the Primary and Secondary Vacuum Units 11
 Connecting the Drain Hose to the Drain 11

ELECTRICAL HOOKUP..... 12
 Electrical Installation Requirements..... 12
 Main Power Connection 12
 Connecting the LED Push-Button Controls (Conditional) 13
 Connecting the Third-party Remote Control (Conditional) 13
 Tandem Vacuum Units Electrical Connection..... 13

INITIAL COMMISSIONING..... 14

VACUUM SYSTEM STATUS INDICATORS 14

WIRING DIAGRAM 16



IMPORTANT SAFETY INSTRUCTIONS

Identification of Danger Levels

To prevent personal injury and property damage, users must carefully review all safety information presented throughout this document.

Critical warnings and safety precautions are distinctly identified using formatting techniques designed to emphasize their importance. Disregarding these safety guidelines may result in serious harm to individuals or damage to equipment and facilities.

All operators have an obligation to thoroughly study and comply with the provided safety information. Please contact the manufacturer immediately if any part of the safety instructions is unclear or requires further explanation. We aim to promote safe, hazard-free usage of this equipment.

 WARNING	It refers to a potentially dangerous situation that could cause severe injury or death. These situations should be clearly identified, and preventive measures provided. Users must be aware of the risks and comply with safety guidelines to prevent harm.
 CAUTION	It refers to a potentially hazardous scenario that could cause minor bodily injury. These situations should be identified and safety measures provided to mitigate risk. Users must comply with safety guidelines to avoid injury.
 NOTE	It refers to a potentially damaging situation that could harm the product or its surroundings. Precautions should be taken to prevent damage.

BEFORE YOU BEGIN



To ensure proper installation and operation of dental equipment utilities, it is imperative that all plumbing, electrical, and construction work be completed by licensed professionals in accordance with current local codes and regulations.

1. Verify that all electrical connections and vacuum unit hoses are securely attached per the installation guidelines.
2. Using a multimeter, check that the input voltage is within the specified operating range of 200-240 VAC for this equipment. Also confirm there is a proper ground connection according to electrical code.

Electrical Specifications		ADS V3	ADS V5	ADS V7	ADS V10	ADS V14
Power Supply	Voltage	200-240 VAC	200-240 VAC	200-240 VAC	200-240 VAC	200-240 VAC
	Phases/ Frequency	1 phase / 60 Hz	1 phase / 60 Hz	1 phase / 60 Hz	1 phase / 60 Hz	1 phase / 60 Hz
Rated Power	Horsepower (hp)	2.5	2.9	3.2	2.9 x 2	3.2 x 2
Current Draw	Full Load Amps	9	10	11	10 x 2	11 x 2
	Minimum Breaker Rating	25	25	25	25	25
Minimum Wire Gauge		12	12	12	10	10

- If the voltage is outside of the acceptable range, a buck-boost transformer providing +/- 10% adjustment may be required.
- Ensure the intake, drain, drip leg, and exhaust hoses are of sufficient length to reach their designated connection points

in your facility. Any necessary piping extensions should be installed by a qualified plumber to reach the equipment. Note the exhaust hose must not be trimmed.

- Examining the room's airflow vents and taking temperature measurements to verify the ambient temperature remains within the ideal range of 40-104°F. Make any needed adjustments to the HVAC system or ventilation to maintain proper thermal conditions. For any ongoing temperature control issues, facility modifications may need to be considered.

Recommended Tools

To complete utility and accessory installations on ADS equipment per manufacturer specifications, the following tools should be readily available:

- Spirit level
- Hose clamp wrench (provided)
- Phillips head screwdriver
- Adjustable wrench
- Tubing cutter
- PVC cement
- 3/8" hex driver
- 1/16" socket and ratchet wrench

EQUIPMENT SIZING SPECIFICATIONS

Model	Users*	Inches Hg**	SCFM***
ADS V3	3 - 5	7.5	33.5
ADS V5	5 - 7	7.5	44.1
ADS V7	7 - 10	7.5	56.8
ADS V10	10 - 14	7.5	44.1 × 2
ADS V14	14 - 20	7.5	56.8 × 2

* Number of simultaneous users under normal operation

** Vacuum level measured in inches of mercury

*** Standard cubic feet per minute of airflow

Installation Dimensions		
Model	Width x Depth x Height	Weight
ADS V3	15 × 17 × 48.8 inches	191 lbs
ADS V5	18 × 19.3 × 48.7 inches	216 lbs
ADS V7	18 × 19.3 × 48.7 inches	238 lbs
ADS V10	(18 × 19.3 × 48.7) × 2 inches	227 x 2 lbs
ADS V14	(18 × 19.3 × 48.7) × 2 inches	249 x 2 lbs

Packaged Dimensions		
Model	Width x Depth x Height	Weight
ADS V3	21.5 × 22.7 × 52.3 inches	235 lbs
ADS V5	23.4 × 26.6 × 55.7 inches	262 lbs
ADS V7	23.4 × 26.6 × 55.7 inches	286 lbs
ADS V10	(23.4 × 26.6 × 55.7 inches) × 2	273 x 2 lbs
ADS V14	(23.4 × 26.6 × 55.7 inches) × 2	297 x 2 lbs

VACUUM UNIT CLEARANCE REQUIREMENTS

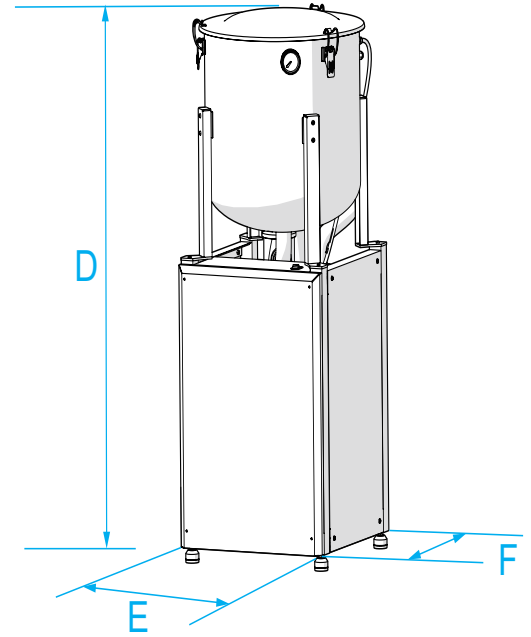
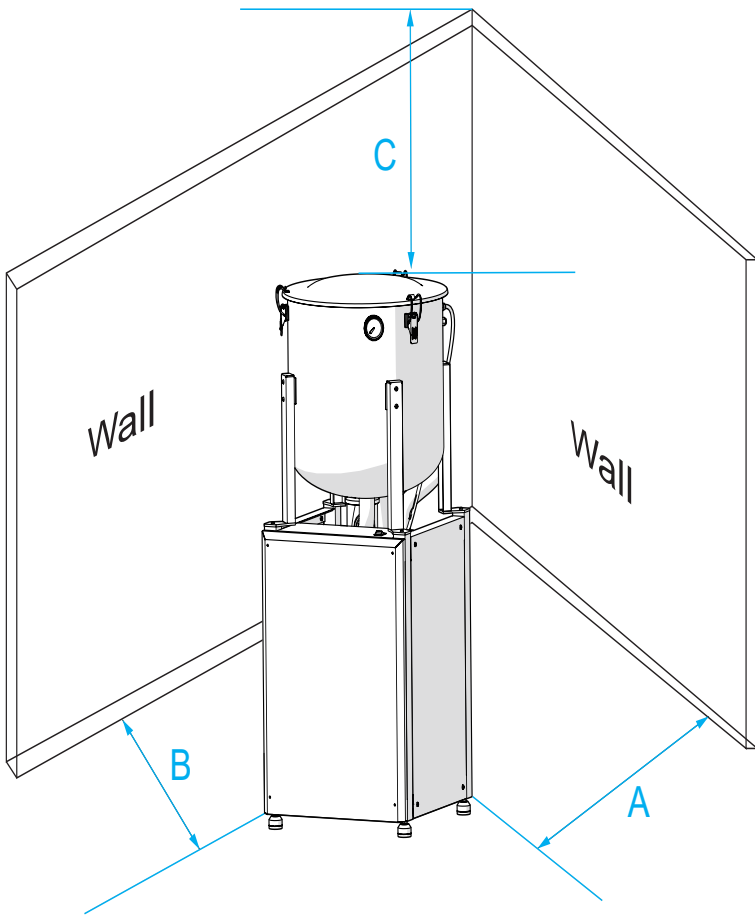

A	Provide a minimum of 9 inches of clearance behind the vacuum unit and any rear obstructions. This clearance is needed for ventilation and access to the back panel.
B	Allow at least 4 inches of clearance on each side of the vacuum unit, including between multiple adjacent vacuum units. This ensures proper airflow and access for maintenance.
C	Maintain at least 12 inches of clearance between the top of the vacuum unit and any overhead obstructions. This allows adequate ventilation and service access.
D	Product height, see installation dimensions listed on page 3.
E	Product width, see installation dimensions listed on page 3.
F	Product depth, see installation dimensions listed on page 3.

VACUUM UNIT INSTALLATION



WARNING

Proper ventilation is required

Provide at least 1 inch clearance between the bottom of the vacuum unit and the floor. This allows adequate air intake.

Before Installation

1. Remove the product's outer packaging box.
2. Remove the fixing screws on the front panel and side panels (4 screws on each panel), and take down the panels.

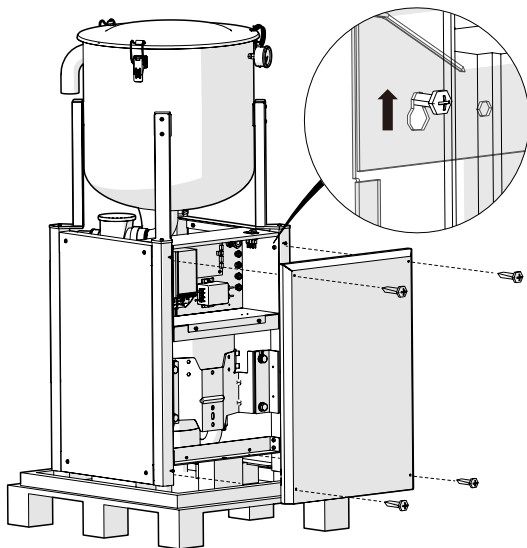

Remove Front Panel

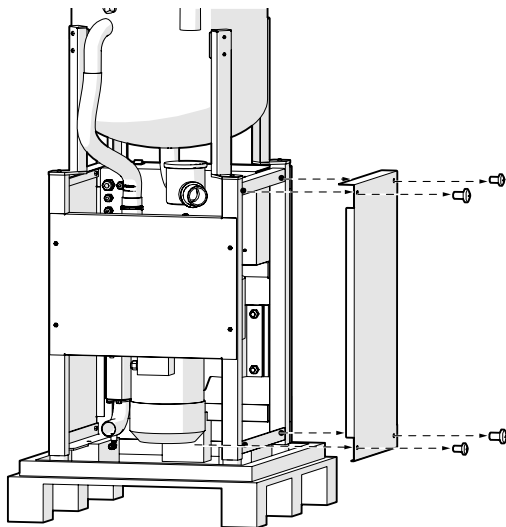

Remove Side Panel

3. Remove the screws that fixing the unit to the pallet.

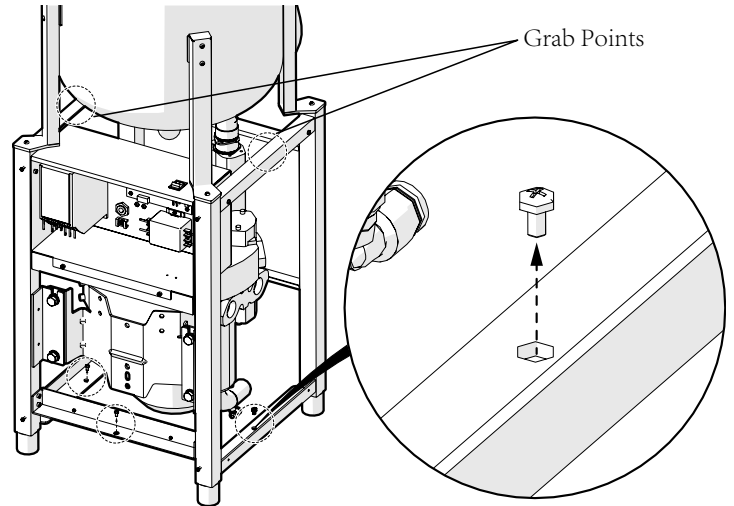

4. Grasp the grab points. Lift the unit off the wooden pallet.
5. Release safety latches and remove the lid of the separator tank.
6. Locate two cable ties on float switches in the tank, cut and discard them.
7. Close the lid and secure the safety latches.

Single Vacuum Unit Installation

Single Vacuum Unit - Overhead Intake

This overhead setup uses a roof vent for vacuum exhaust. The vent is shielded to prevent rain and animal access. Exhaust hose routes from the vacuum unit to the vent.

- Roof exhaust vent with shroud and screen to protect from weather and animals.
- Exhaust hose running from vacuum unit to roof vent.

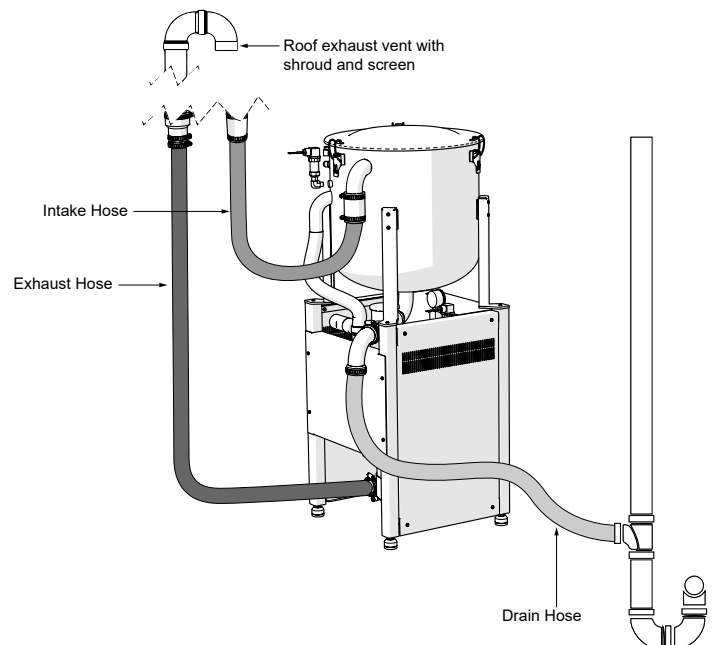

Single Vacuum Unit - Below Grade Intake

The island setup places the vacuum unit in the room center. Intake and exhaust hoses route under the floor to the utility room wall for drainage, exhaust venting, and vacuum unit connection.

- Roof exhaust vent with shroud and screen to protect from weather and animals.
- Vacuum unit positioned on island in center of room.
- Intake and exhaust hoses routed under floor.
- Hoses connect to utility room wall for drainage and exhaust.

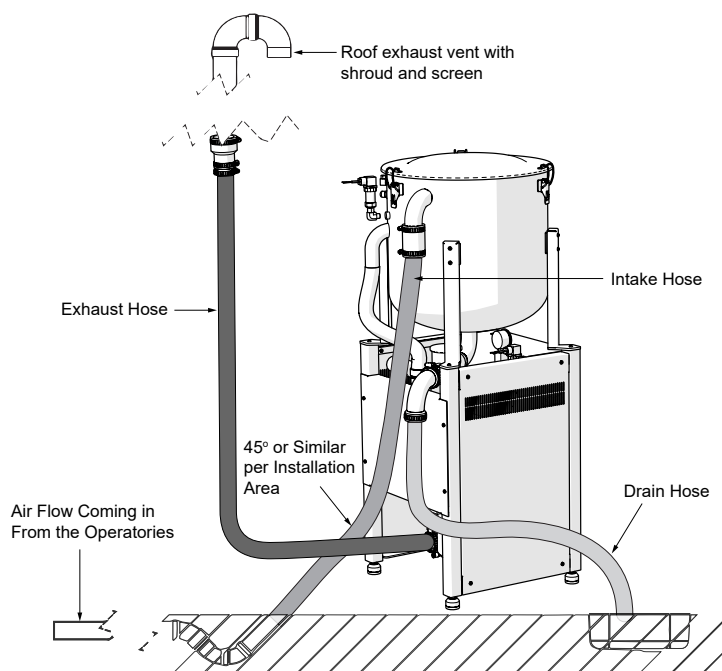

Vacuum Unit Leveling Procedure

1. Place the vacuum unit in the intended installation location. Make sure to allow access for service.
2. Set a spirit level tool on top of the unit, positioning it along one side.
3. Examine the bubble vial indicator on the level. Adjust the height of the feet on that side up or down until the bubble is perfectly centered. This indicates that side is level.
4. Move the level tool perpendicular to the other side and again adjust the feet until the bubble vial shows level for that axis.
5. Repeat on the front and back sides, altering foot heights until the bubble remains centered as the level is placed along each orientation.
6. Verify the vacuum unit does not rock or wobble when gently shaken. If so, continue adjustments until completely stable.

7. Double check that ventilation openings are unobstructed. Blocked air flow leads to overheating and pump damage.
8. Keep the area around the unit clean and free of clutter. Obstructions increase fire hazards.

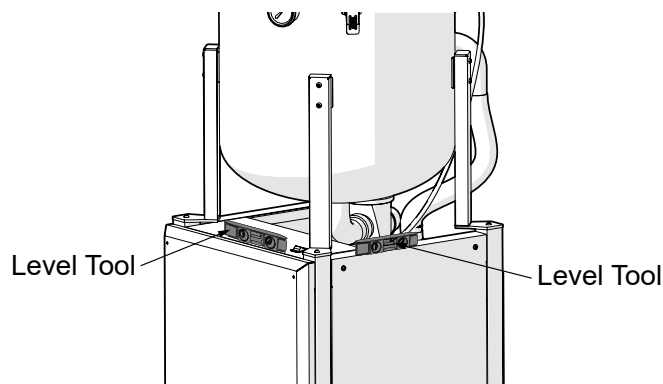

Vacuum Unit Hose Connections

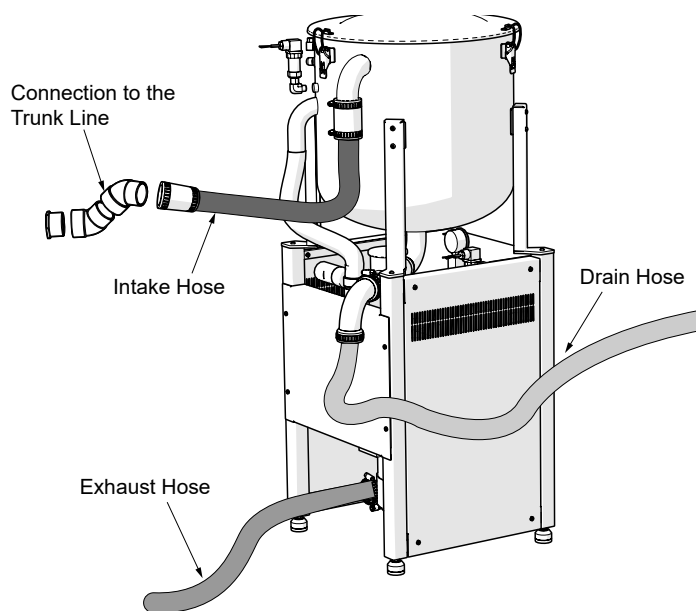

Avoiding Unsuitable Vacuum Unit Fittings

Only use vacuum unit fittings that meet the exact specifications provided in the equipment documentation. Follow all trunk line connection guidelines outlined in the installation manual.

Improper fittings can lead to poor vacuum, inability to efficiently remove fluids, and possible pump damage from overwork. Ensure all vacuum plumbing follows the manufacturer's instructions for optimal functionality. Contact technical support with any vacuum line installation or fitting usage questions.

The following types of fittings must NOT be used when connecting vacuum unit hoses or constructing the main vacuum trunk line:

- 4-way crosses
- Short elbow connectors

- Tee connectors
- Any fitting not explicitly approved by the manufacturer



These undersized or restrictive fittings reduce air flow rates throughout the system. This can severely diminish vacuum performance.

Connecting the Intake Hose to the Trunk Line

1. Measure and cut the intake hose to the exact length required for optimal routing and to avoid excess hose slack.
2. Route and position the intake hose in a manner that prevents sagging and the formation of low spots where debris collection could occur.
3. Provide proper support for the intake hose routing using hangers, clamps, or other mounting hardware as necessary.

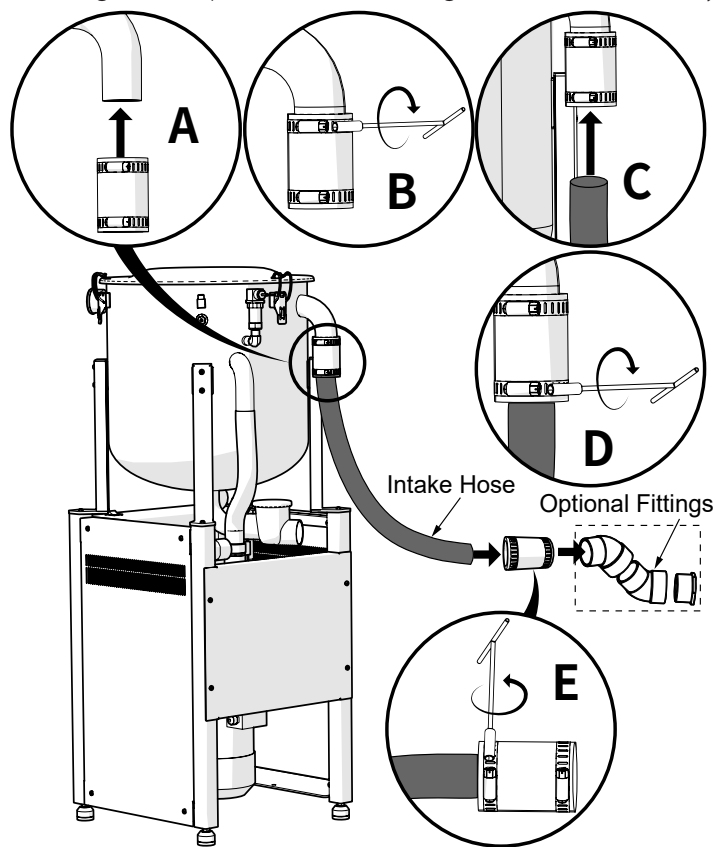

Connecting the Drain Hose to the Vacuum Unit

1. Use the provided hose clamp to securely fasten the drain hose to the drain outlet on the vacuum unit. Tighten the clamp sufficiently to prevent leakage.
2. Position the connection so the drain hose routing aligns properly with the desired drain location. The drain connection on the vacuum unit can be rotated 240 degrees to accommodate the required positioning.
3. Ensure the drain hose slopes downward away from the vacuum unit to facilitate gravity drainage. Slope at least 1/4 inch per 10 feet of hose length.

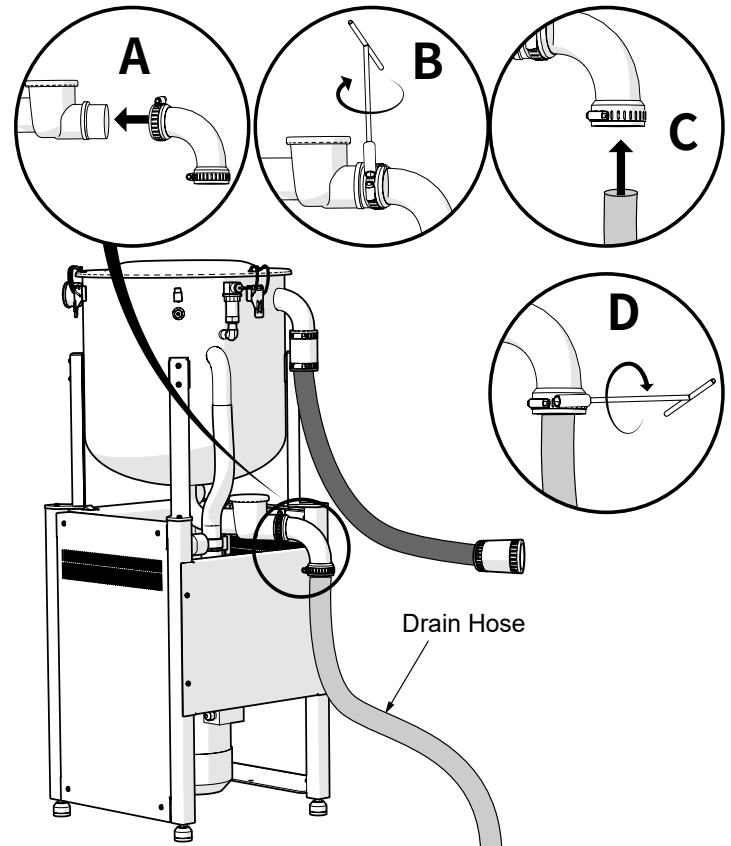

Connecting the Drain Hose to a Floor Sink/Drain

1. When connecting to a floor sink or drain, insert the drain hose directly into the drain opening.
2. Confirm a tight fit between the hose and drain to avoid leakage.
3. Position the assembly to enable straight, downward routing of the drain hose into the floor sink/drain.

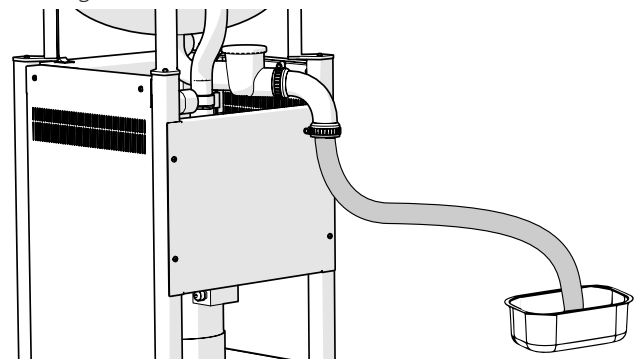

Connecting the Drain Hose to the Drainage System



NOTE

The drain hose must be connected to a vented or open sewer drain capable of handling 10 gallons of waste water with 30 seconds.

Connecting the Drain Hose to a Pipe Stub with an Air Gap

1. Attach the drain hose to a pipe stub above the drain tile or sink to maintain an air gap.
2. Slope the hose at least ¼ inch downward per 10 feet to enable gravity drainage.
3. Maintain the required air gap separation between the drain hose and wastewater plumbing per local codes.

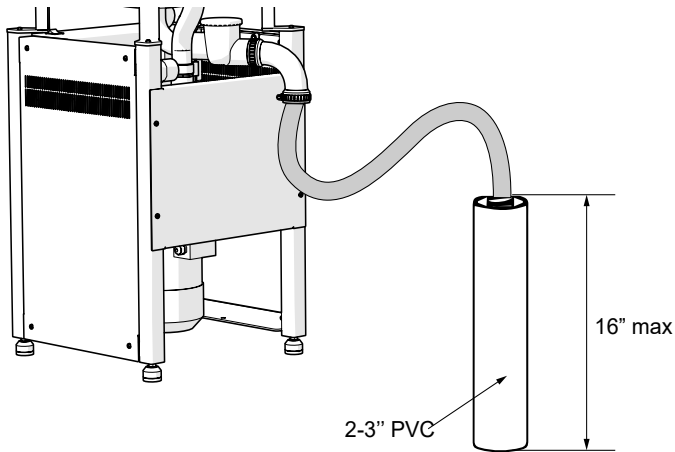

Connecting the Drain Hose Directly to the Vent

1. If permitted by local codes, the drain hose may connect directly into a vent stack.
2. Ensure the connection is properly secured and sealed.

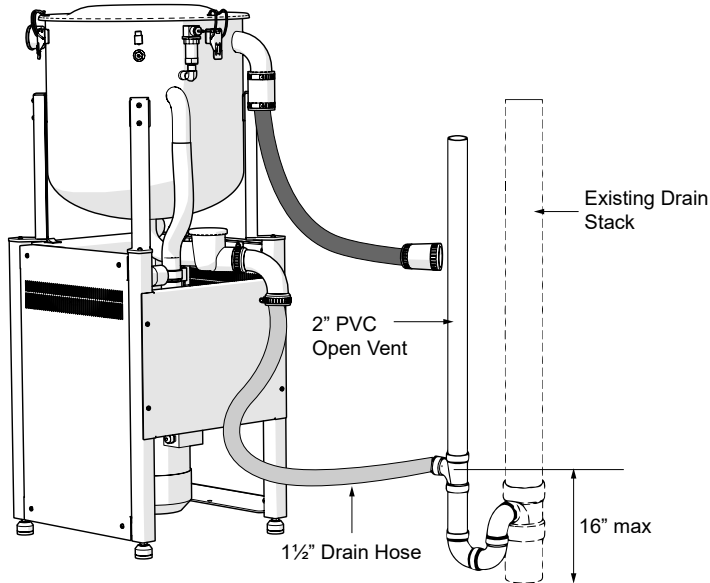

Connecting the Exhaust Venting

1. Install the exhaust hose at full length as provided. Do not trim or modify the exhaust hose length.
2. Coil any excess exhaust hose loosely on the floor behind the vacuum pump. This prevents kinking of the tubing.
3. Vent the exhaust outside per NFPA guidelines and local codes.

4. Measure and trim the drip leg hose to optimal length for proper routing to the floor drain.
5. Position the drip leg hose such that it connects to the drain lower than the exhaust elbow. This enables gravity drainage and prevents water backup into the dry vacuum system.
6. Connect the drain hose to the drain outlet.
7. Once finished all the hoses connection, reinstall the front and side panels and fix with screws (4 screws on each panel).

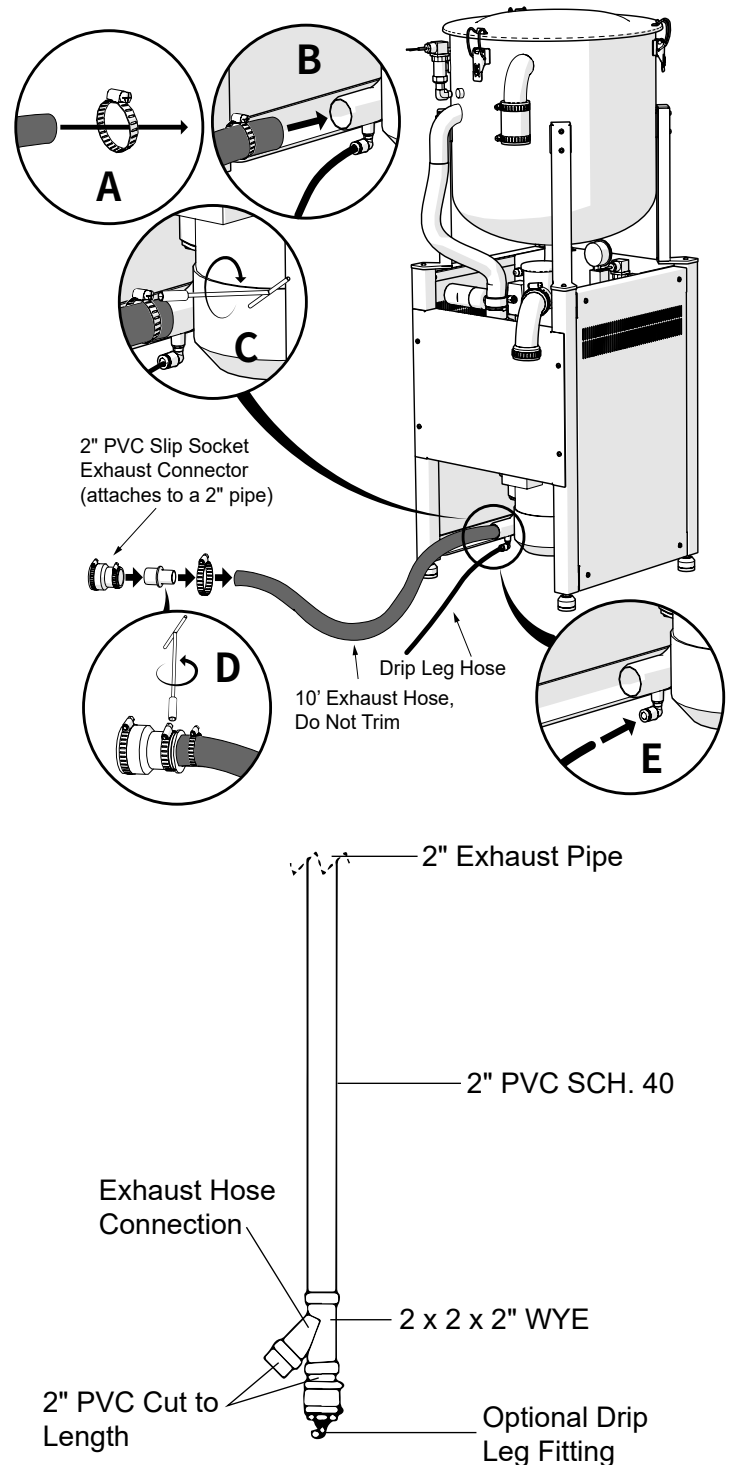

Connecting the Washdown Waterline



CAUTION

Local regulations require licensed plumbers and electricians to perform utility installations. All plumbing and electrical work must comply with prevailing building codes.

- Installation of a washdown waterline system is mandated for endodontic clinics.
- ADS strongly recommends implementing the optional washdown system in all dental office settings.

Connect the 3/8" washdown waterline to the city water supply system

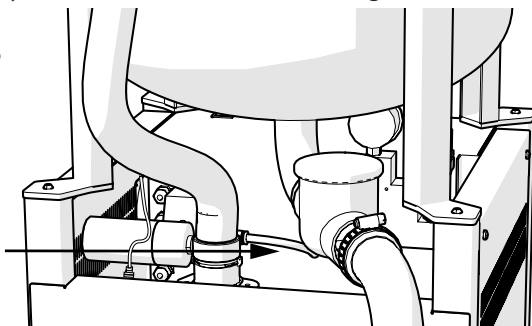

NOTE

Depending on local plumbing codes, connecting the washdown waterline may necessitate installing a backflow preventer.

Tandem Vacuum Units Installation

ADS dry vacuum system can be installed as tandem vacuum units (ADS V10 and ADS V14) to increase vacuum capacities.

Tandem vacuum units work as follows:

- After the installation and setup of the tandem vacuum units, only the primary vacuum unit is running.
- If the primary vacuum unit satisfies both of the following conditions, the secondary vacuum unit starts:
 - Vacuum level (negative pressure level in the separator tank) is below a specific threshold.
 - Frequency is above a specific threshold for a specific duration.
- If the frequency of a primary vacuum unit is less than or equals to a specific threshold for a specific duration, the vacuum unit stops and becomes a secondary vacuum unit.

Tandem vacuum units must be the vacuum units of the same model. Mixing different models is not supported.

For connecting more than three vacuum units in tandem, contact ADS Customer Service for guidance.

Tandem Intake Manifold Assembly

The manifold can be configured to accept air intake from either side. Assemble it according to the installation location's requirements.

The parts for assembling the tandem intake manifold are included with orders for tandem dry vacuum systems.

When assembling, note the markings on the manifold indicating which side should be facing up, and the arrow showing airflow direction from the manifold into the vacuum units.

1. Install the check valves in the proper orientation according to the markings. The valves ensure airflow travels in one direction - from the manifold into the vacuum units.
2. Connect the open ends of the manifold to the intake hoses leading to the separator tanks. Secure the connections with hose clamps.
3. Ensure all connections are airtight. Seal with additional clamps or tape if needed.

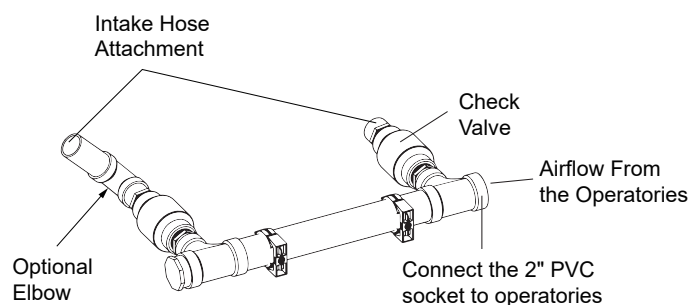

Tandem Vacuum Units - Overhead Intake

1. For tandem setups, trim the intake hoses to create the shortest, smoothest runs from the manifold to the tank inlets. This optimizes airflow.
2. Connect the intake hoses directly into the top of the collection tanks when an overhead intake is required. Use the provided elbow fittings if needed.
3. Cut the intake hoses to appropriate lengths to avoid kinks or bends that could restrict airflow into the tanks.
4. Ensure the tank inlets remain unobstructed. Route the hoses downward into the tanks at a straight vertical angle.
5. Position the vacuum units side-by-side and level to evenly distribute workload. This allows balanced operation.
6. Follow all local electrical codes when wiring dual motor power connections.

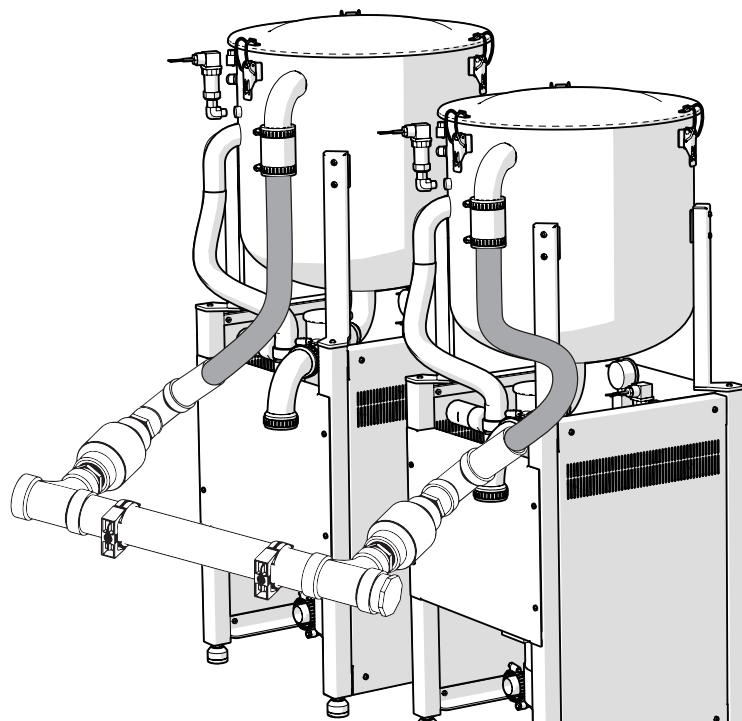
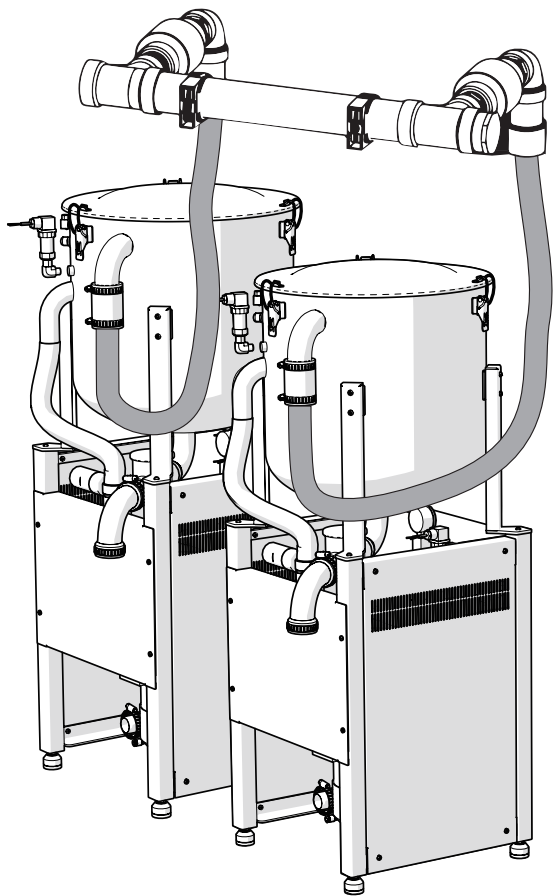

Tandem Vacuum Units - Below Grade Intake

1. For tandem vacuum unit setups, trim the intake hoses to create the shortest and smoothest runs from the manifold to each tank inlet. This optimizes airflow.
2. Connect the intake hoses directly into the bottom of the collection tanks, below the grade level of the tanks. This enables gravity drainage of fluids into the tanks.
3. Ensure the tank inlets are unobstructed by cutting the hoses to appropriate lengths. Avoid kinks or bends that restrict airflow.
4. Position the vacuum units side-by-side and level to each other. Leveling evenly distributes workload across both systems for balanced operation.
5. Follow all local electrical codes when wiring dual motor power connections.

Attaching and Leveling the Intake Manifold

1. Use the included brackets to mount the intake manifold assembly securely in the desired location.
2. Attach the brackets to a sturdy surface using appropriate hardware for the material (not included).
3. Position the manifold assembly horizontally and attach it to the brackets using the provided screws.
4. Ensure the manifold is completely level by checking with a spirit level tool.
5. Small leveling adjustments can be made by inserting washers between the brackets and manifold.
6. With the manifold leveled, connect the open ends to the intake hoses leading to the separator tanks using hose clamps.
7. Verify the hose connections are straight, smooth, and do not place stress on the manifold assembly.

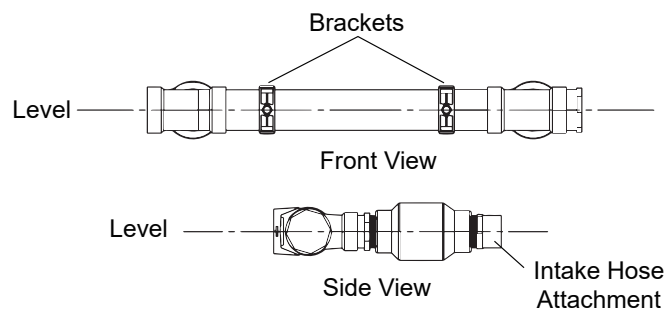

Connecting the Intake Hose to the Trunk Line

The process for connecting the intake hose to the building's trunk line is the same whether the hose is coming directly from the tank inlet or from a tandem manifold assembly.

1. Route the intake hose to the connection point on the trunk line. Cut the hose to the appropriate length to avoid kinks.
2. Use a connector fitting and hose clamps to securely attach the intake hose to the trunk line. Verify an airtight seal.
3. For overhead trunk line connections, install the provided 90° elbow fitting onto the hose to route the connection upwards.
4. For below grade trunk lines, route the intake hose downward at the connection point for drainage by gravity.
5. Support the intake hose properly along its run to avoid stress on the connections.

Connecting the Exhaust Hoses

1. Do not trim or cut the exhaust hose. It must remain at full length to properly muffle sound.
2. Route the drip leg hose to a drain so that it sits lower than the exhaust elbow on the separator tank.
3. Use the provided hose clamps to securely connect the drip leg hose to a drain pipe or receptacle. Verify an airtight connection.
4. Support the exhaust hose along its run to avoid sagging and maintain the downward slope for proper drainage.

Connecting Exhaust for Two Vacuum Units

- Use 3" PVC schedule 40 pipe for the main exhaust line.
- Install a 3" x 3" x 2" wye fitting to split the main line into two 2" branch lines.
- Only use one 3" x 3" x 2" wye per exhaust line.
- Cut lengths of 2" PVC pipe to connect the wye to the vacuum unit exhaust hose connectors.
- Install 2" x 2" x 2" wye fittings to connect the exhaust hoses from each vacuum unit.
- Cut the 2" PVC to appropriate lengths between fittings to avoid stress on the connections.

- Use 3" to 2" reducer fittings to connect the 2" pipe into the 3" main exhaust line.
- Optional: Install drip leg fittings at low points to drain condensed moisture.

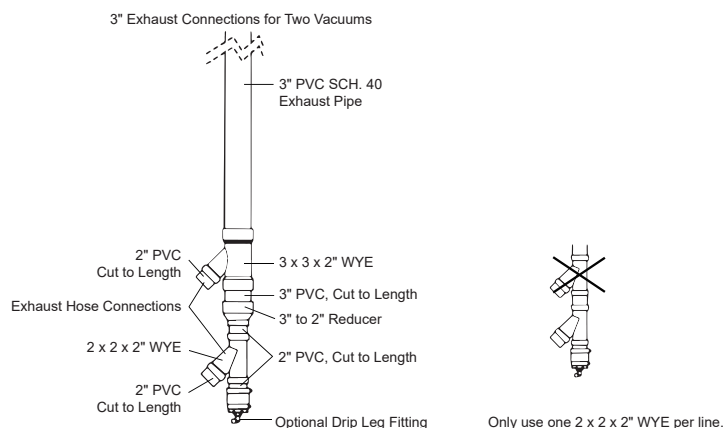

Setting the Primary and Secondary Vacuum Units

Tandem vacuum units start and stop based on a mechanism that depends on whether the unit is primary or secondary. For details, see "Tandem Vacuum Units Installation" on page 9.

To set the primary and secondary vacuum units:

1. Remove the service panels from the front of the vacuum units.
2. Set the dial switches on the internal circuit boards of the vacuum units as follows:

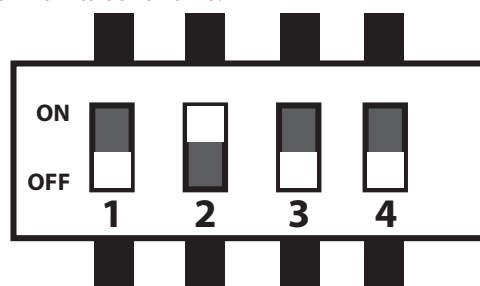

- For the selected initial primary vacuum unit, set the **1** dial switch to the **OFF** position, and set the **2** dial switch to the **ON** position.
- For the selected initial secondary vacuum unit, ensure that the **1** and **2** dial switches are in the **OFF** positions.

Connecting the Drain Hose to the Drain

1. Route the drain hose from the separator tank to a suitable drain location.
2. Cut the hose to an appropriate length to avoid kinks and

stress on the connections.

3. Attach the drain hose to the drain pipe or receptacle using the supplied hose clamp. Verify an airtight connection.
4. Position the drain hose to create a constant downward slope. This allows separated liquid to drain by gravity.

5. Install a p-trap if connecting to a drain pipe. This prevents sewer gases from backing up into the system. Do not trim the drain hose excessively. Some slack is needed to allow for proper routing and drainage.
6. Support the drain hose along its run to maintain the downhill slope and avoid sagging.

ELECTRICAL HOOKUP

Electrical Installation Requirements



WARNING

Electrical wiring and connections must adhere to National Electrical Code (NEC) standards and prevailing local codes. To start or stop the vacuum unit, use the remote control and **Mster Switch**. Do not start or stop the vacuum unit by toggling the main utility power supply. Adhering to NEC guidelines, local codes, and the manufacturer's instructions for electrical set up and operation ensures safe, trouble-free performance of the dental dry vacuum system.



CAUTION

To comply with local regulations, all plumbing and electrical work must be performed by licensed professionals. Plumbers should handle all water supply lines, drains, and sewer connections. Electricians should perform electrical installations and wiring.

To ensure safe operation, all electrical wiring and connections must adhere to the following:

- National Electric Code (NEC), NFPA 99C, and local regulations. A licensed electrician should perform installations.
- The system requires a dedicated 20 or 30 amp circuit branch. Do not connect other equipment to the circuit.
- An external disconnect switch that breaks all supply conductors must be incorporated. This allows isolation during service.
- Only operate the unit within the specified 200~240 VAC voltage range. Fluctuations outside this rating can severely damage components.
- Never use a buck-boost transformer. The system requires direct stable voltage from the mains supply.
- Improper electrical setups present shock hazards. Failure to follow requirements can result in injury or equipment failure.

- See the Site Specifications and Sizing Information section on page 4 for full electrical details. Following the prescribed installation guidelines ensures safe, trouble-free operation of your dental dry vacuum system.

Main Power Connection



WARNING

Electrical shock hazard

The system must be properly earth grounded. Only connect to a mains supply with a protective earth conductor.

- A licensed electrician should install a dedicated hard-wired disconnect box. This allows isolation of the vacuum supply.
- The unit requires a 3-wire service (Hot/Hot/Ground). A 6-foot power cord is provided.
- Failure to follow electrical guidelines can result in serious injury. Proper grounding and wiring by qualified technicians is mandatory for safe operation.
- Do not attempt connection without understanding wiring specifications. Consult a licensed electrician if unsure of how to correctly establish the mains supply hookup.
- Refer to equipment documentation for full electrical ratings before setting up service connections.
- Following prescribed electrical protocols protects users and prevents damage to the dental dry vacuum system.

terminal strip, according to the following table.

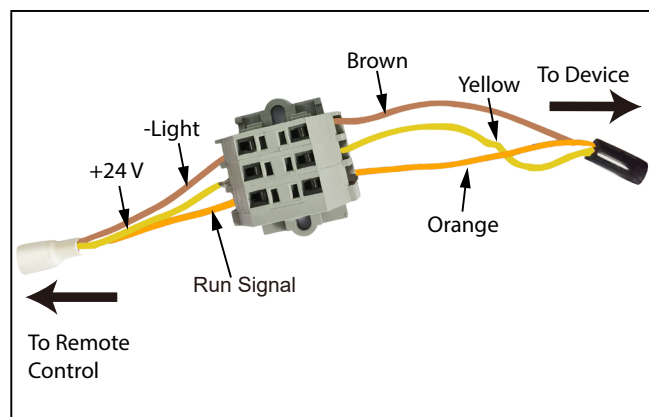
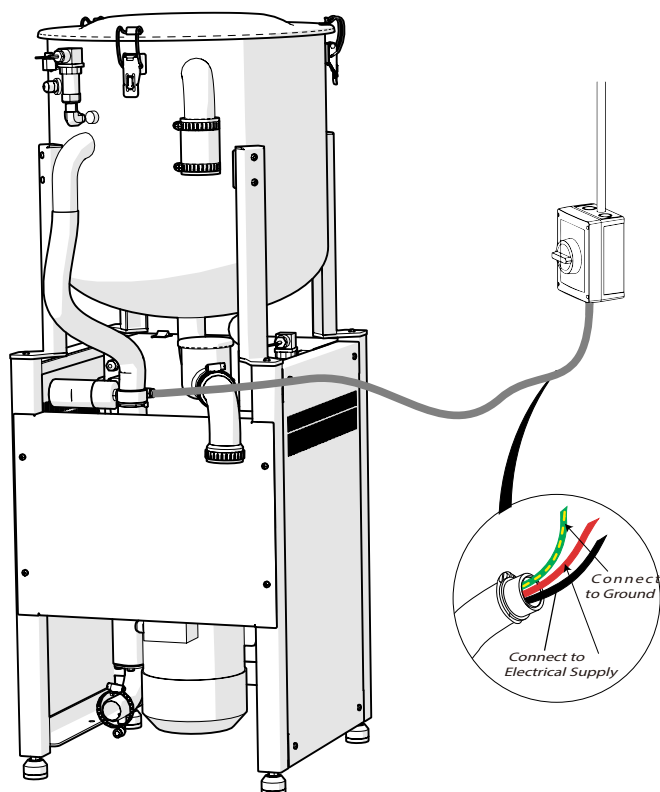

Mfg/Wire	Brown (-Light)	Yellow (+24 V)	Orange (Run Signal)
Air Techniques	Brown	Yellow	Orange
A-dec	Gray	Blue	Black
Midmark	White	Blue	Red
Dental EZ	Brown	Black	Yellow
Matrix	Blue	Red	White
Apollo	White	Blue	Red
Tech West	White	Blue	Red

Connecting the LED Push-Button Controls (Conditional)

Optionally, the dry vacuum system can include LED illuminated push-button controls for convenient start and stop operations. If including the LED illuminated push-button controls, proper connection of these controls is a must and important for their functionalities.

For details, refer to the user guide of the LED push-button controls.

Connecting the Third-party Remote Control (Conditional)

The dry vacuum system supports third-party remote controls for convenient start and stop operations.

To connect the third-party remote control:

1. Connect lead wires from the control unit to the extension wires, if needed.
2. Route the wires from the LED push buttons to the location of the terminal strip.
3. Remove the included remote control lead wires from the terminals in the terminal strip, if any.
4. Attach the lead wires of the vacuum unit and the third-party remote control to the appropriate terminals in the

5. Secure the connections tightly.
6. Follow the remaining steps of the third-party remote control installation.

For details, refer to the support documentation of the third-party remote control.

Tandem Vacuum Units Electrical Connection

1. Ensure both vacuum units are stopped and disconnected from the power supply.
2. Connect the tandem cable between the two vacuum units. This cable coordinates operation of the two vacuum units.

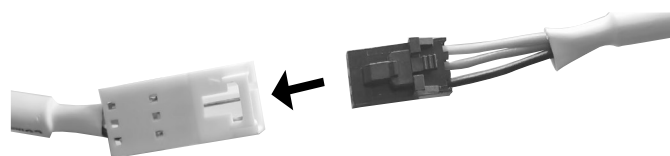

3. Ensure that the dial switches are set up according to "Setting the Primary and Secondary Vacuum Units" on page 11.
4. Reconnect both vacuum units to the power supply.

5. Set **Master Switches** of both vacuum units to **REMOTE**.



NOTE

A long interval between the switch setting actions can cause the failure of the vacuum unit connection.

6. Wait until the **ON_LINE** status lights on the circuit boards of the vacuum units are flashing at a fixed frequency. If the **ON_LINE** status lights are not flashing as expected, which indicates the connection failure, repeat this procedure.

INITIAL COMMISSIONING



WARNING

This equipment may initiate operation automatically without prior notification. Exercise caution when working in proximity.

- Perform visual inspection for any shipping or installation damage.
- Validate electrical connections and verify 200-240 VAC supply voltage.
- Energize main disconnect switch/circuit breaker. Power on vacuum unit and confirm activation. Refer to status indicators if needed.
- Check vacuum gauge reading against specifications in documentation.

- Test vacuum force at all HVE and SE terminals for proper performance.
- Thoroughly inspect all connections and piping for air leaks. Repair any identified deficiencies.
- Stop a vacuum unit and verify that washdown sequence can be initiated after 45-60 seconds (if installed). Listen for solenoid valve opening water supply and inspect drain check valve to confirm drainage.
- Inspect drain hose for unobstructed flow. Ensure no low points trapping debris.
- Set **Master Switch** to **REMOTE**.
- With remote controls, test **on** and **off** functionalities.
- Document successful activation and functionality testing for records.

VACUUM SYSTEM STATUS INDICATORS

Located on the internal circuit board, status lights provide real-time operational information to aid troubleshooting.

To view indicators, remove the front service panel. The lights indicate current system conditions and modes. If the status lights do not resolve an observed issue, contact ADS technical support for assistance.

- LD1.  R10  ON
- LD2.  R11  ACTIVATE
- LD3.  R12  RINSE
- LD4.  R13  ON_LINE

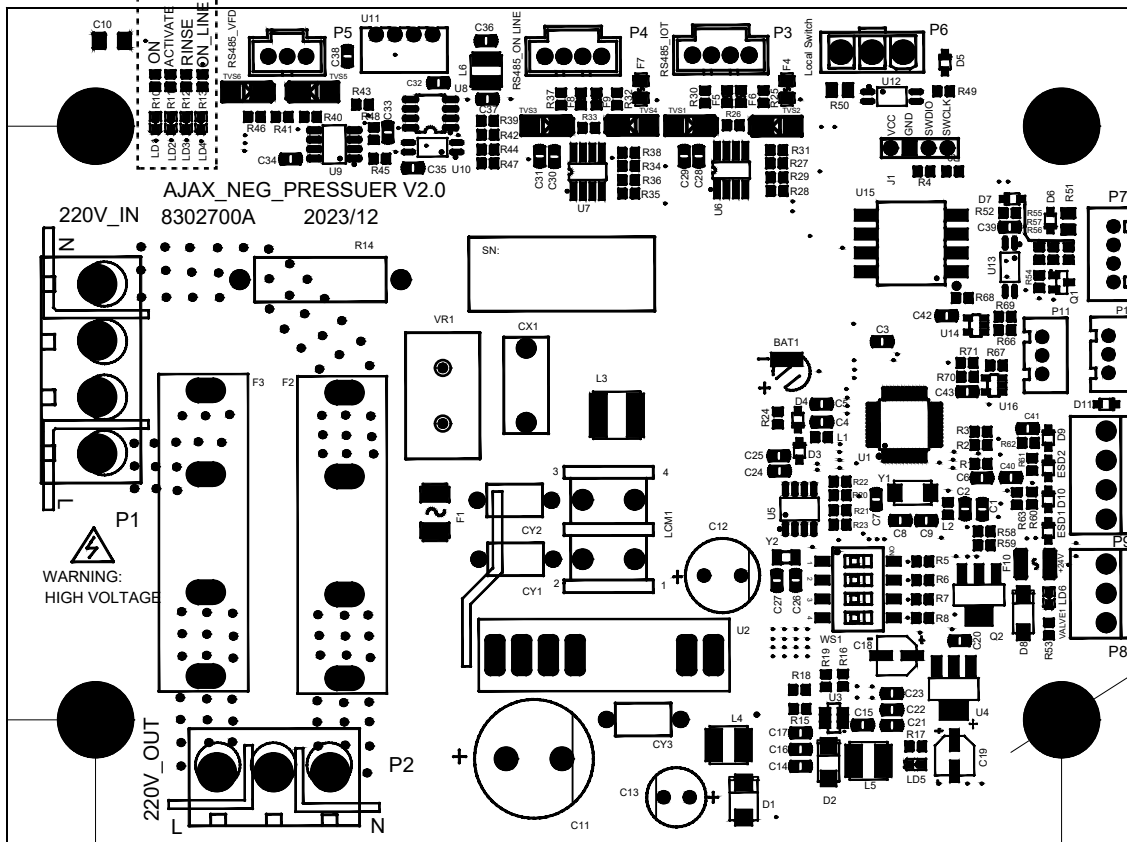

Status Lights on the Internal Circuit Board	Mean This ...
The ON light is on.	The vacuum unit is connected to main power.
The ACTIVATE light is on.	The vacuum unit is running.
The RINSE light is on steadily.	The vacuum unit is in the drain and rinse cycle.
The ON_LINE light is flashing at a fixed frequency.	The vacuum is in normal communication.
The ON_LINE light is off.	The vacuum communication is interrupted.

WIRING DIAGRAM

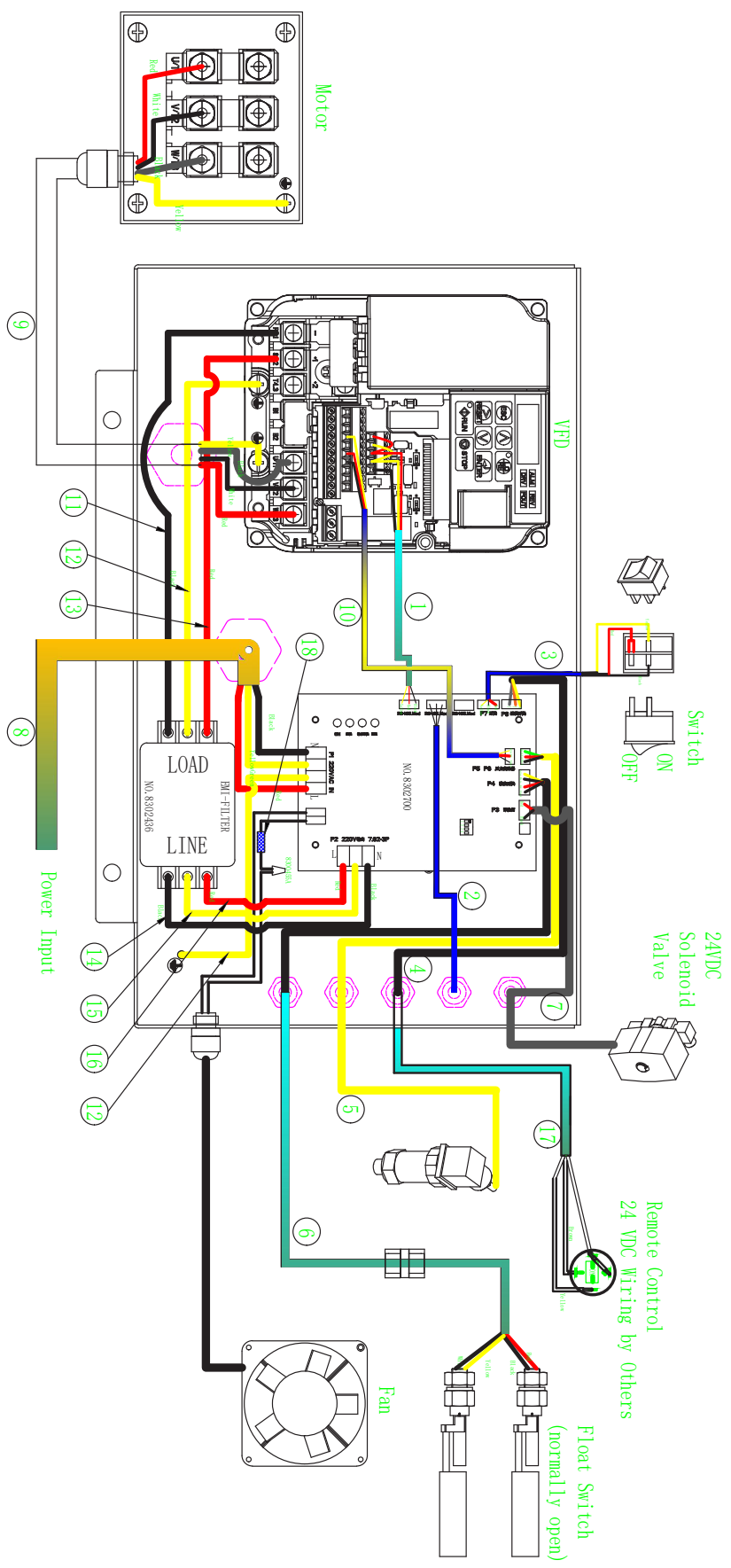



ADS Dental System

ADS Dental System

📍 Add: 1590 S Milliken Ave., unit A, Ontario, CA 91761

✉ E-mail: sales@adsequip.com

☎ Tel: (626)620 0456

📞 Technical Support: 800-488-9708

🌐 www.adsdental.com / www.adsequip.com

● P/N: 8502707 ● Rev. D ● Issue Date: 2024/11/29